



metal buildings

roofs

walls

slabs

foundations

INTERIOR HIGH-HUMIDITY METAL BUILDING INSULATION Installation Procedures For THERMAX Insulations

Metal building interiors and contents subjected to prolonged high-humidity conditions, such as buildings that house swimming pools, ice rinks or food processing services, are often damaged by dew point condensation. A two-layer system of THERMAX* Sheathing along with THERMAX Metal Building Board, THERMAX Light Duty, THERMAX Heavy Duty or THERMAX Heavy Duty Plus insulation will help control moisture vapor and energy loss in high-humidity metal buildings (relative humidity greater than 50 percent), as well as buildings with dark roofs. All varieties of THERMAX insulation are non-structural, rigid boards consisting of a glass-fiber-reinforced polyisocyanurate foam core laminated with various pinhole-free aluminum foil facers. The uniform, closed-cell core foam is exceptionally resistant to heat flow, while the noise-dampening facers help provide an effective barrier to moisture and air infiltration.

There are three methods that can be used to install THERMAX insulation products in multiple layers. Each method is outlined here.

General Information

- THERMAX insulation products are easy to distinguish. THERMAX Light Duty, THERMAX Heavy Duty and THERMAX Heavy Duty Plus insulations are manufactured with an embossed white acrylic-coated aluminum facer on one side and an aluminum facer on the other side. THERMAX Metal Building Board has embossed aluminum facers on both sides. And THERMAX Sheathing has aluminum facers on both sides.
- Store insulation inside or protect with a tarp to keep dry until use. Prolonged exposure to water may turn the painted surface gray.
- THERMAX insulations can be installed vertically or horizontally.
- THERMAX insulation board joints that are not closed with PVC Clip Strips must be sealed with commercial aluminum foil tape or THERMAX white foil tape. Taping serves as a protection against air infiltration and moisture migration and gives the exterior of the boards a continuous surface.
- Minor scratches and/or nicks may occur during installation. Also, the edges of the foil facer may become slightly curled. These do not affect the product's overall performance. A coat of good-quality latex acrylic or latex enamel paint can be used for touch-ups of the finish boards. (Sherwin-Williams DTM

acrylic coating B66-W201 semi-gloss will provide a good match.) Although no primer is required, follow paint manufacturer recommendations for best results.

- There are two ways to cut THERMAX insulation boards. One way is to use a straight edge and a utility knife, making sure to cut all the way through the facing. Or, THERMAX boards may be cut with a small handsaw. Safety precautions should be taken with either method.

Materials Checklist

To install THERMAX insulations, you will need:

- Utility knife or small handsaw
- Straight edge
- Measuring tape
- Pencil
- Commercial aluminum foil tape
- THERMAX white foil tape
- Squeegee or stiff bristle brush
- Construction-grade sealant
- PVC Clip Strips
- Fasteners and poly washers (such as QUIK Cap, Buildex® Multi-Diameter Insulation Tek® or equivalent)
- Safety glasses

Installing First Layer

THERMAX Sheathing:

1. With square edge joints abutting tightly, fasten THERMAX Sheathing to framing members.
2. Center commercial aluminum foil tape over board joints and apply tape (Figure 1).
3. Use a squeegee or stiff bristle brush to press the tape firmly to the joint. Cut tape with a knife. Do not tear tape.

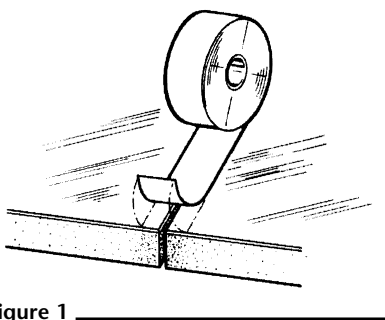

Figure 1

Installing Finish Layer

Good Method

*THERMAX Metal Building Board, THERMAX Light Duty, THERMAX Heavy Duty or THERMAX Heavy Duty Plus** insulation with square edge:*

1. Offset finish board a minimum of 6" in both directions and fasten THERMAX insulation board through the first layer, penetrating 1" into framing members (i.e., girts or purlins) with corrosion-resistant fastener and poly washer, such as QUIK Cap, Buildex Multi-Diameter Insulation Tekes or equivalent (with minimum 1" poly washer). (See Table 1 for fastener lengths.) Each board should span at least three framing members. The maximum span is 5'. Fasteners should be spaced 12" on center in three rows of five fasteners per 48" board width (Figure 2).

Note: If applied above the purlin, lay THERMAX Sheathing board over the first layer of finish board with a minimum offset of 6" in both directions and fasten.

2. Center THERMAX white foil tape or equivalent over edge joints and apply tape (Figure 3).
3. Use a squeegee or stiff bristle brush to press the tape firmly to the joint. Cut tape with a knife. Do not tear tape.

TABLE 1

Recommended Fastener Lengths	
Board Thickness, inches	Fastener Length, inches
1/2 to 5/8	1-7/16
3/4 to 1	1-7/8
1-1/8 to 1-1/2	2-3/8
1-5/8 to 2	3
2-1/4	3-1/4
2-1/2	3-1/2
3	4

Note: Fastener length based on one layer of THERMAX insulation. For the two-layer system, add board thickness of second layer to fastener length recommendation.

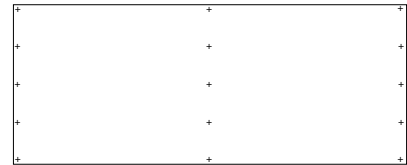

Note: Space fasteners 12" o.c. for wood, metal or concrete attachment.

Figure 2: Fastening Pattern

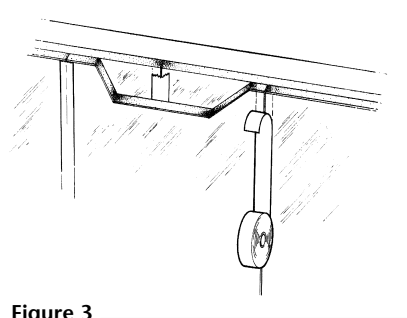

Figure 3

**THERMAX Heavy Duty Plus insulation is designed for use on walls only.

Better Method

*THERMAX Metal Building Board, THERMAX Light Duty, THERMAX Heavy Duty or THERMAX Heavy Duty Plus** insulation with shiplapped edge:*

1. Apply a compatible construction-grade sealant to the shiplapped edge of THERMAX insulation board, following sealant manufacturer instructions. (Contact Dow for a list of suggested sealants.)
2. Offset finish board and fasten through first layer (THERMAX Sheathing), penetrating 1" into framing members (i.e., girts or purlins) with corrosion-resistant fastener and poly washer, such as QUIK Cap, Buildex Multi-Diameter Insulation Tekes or equivalent (with minimum 1" poly washer). (See Table 1 for fastener lengths.) Each board should span at least three framing members. The maximum span is 5'. Fasteners should be spaced 12" on center in three rows of five fasteners per 48" board width (Figure 1).

3. Fit next finish board firmly into the sealant-lined shiplapped edge and fasten.
4. Center THERMAX white foil tape or equivalent over edge joints and apply tape (Figure 4).
5. Use a squeegee or stiff bristle brush to press the tape firmly to the joint. Cut tape with a knife. Do not tear tape.

Best Method

*THERMAX Metal Building Board, THERMAX Light Duty, THERMAX Heavy Duty or THERMAX Heavy Duty Plus** insulation with square edge:*

1. Apply a compatible construction-grade sealant to both flanges of PVC Clip Strip, following sealant manufacturer instructions.
2. Install PVC Clip Strip at long and short edges of THERMAX insulation board.
3. Offset finish board and fasten through first layer (THERMAX Sheathing), penetrating 1" into framing members (i.e., girts or

purlins) with corrosion-resistant fastener and poly washer, such as QUIK Cap, Buildex Multi-Diameter Insulation Tekes or equivalent (with minimum 1" poly washer). (See Table 1 for fastener lengths.) Each board should span at least three framing members. The maximum span is 5'. Fasteners should be spaced 12" on center in three rows of five fasteners per 48" board width (Figure 1).

4. Fit next finish board over Clip Strip flange and fasten through first layer into framing members (Figure 5).

Note: In all of the installation methods, it is important to seal the wall-to-ceiling junction.

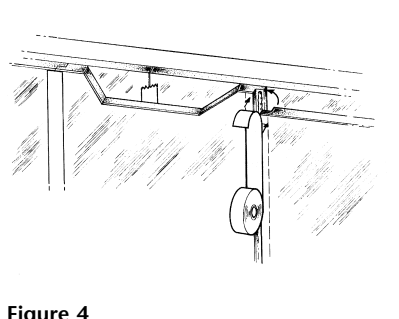

Figure 4

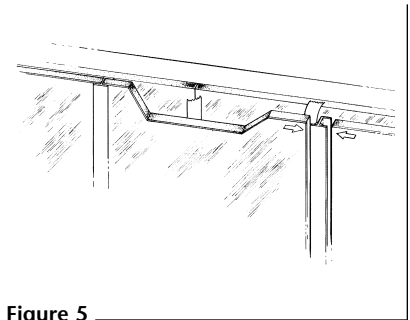

Figure 5

**THERMAX Heavy Duty Plus insulation is designed for use on walls only.

IN THE U.S.:

- For Technical Information: **1-866-583-BLUE (2583)**
- For Sales Information: **1-800-232-2436**

THE DOW CHEMICAL COMPANY

- Building Materials • 200 Larkin • Midland, MI 48674 • www.dowstyrofoam.com/architect

NOTICE: No freedom from any patent owned by Dow or others is to be inferred. Because use conditions and applicable laws may differ from one location to another and may change with time, Customer is responsible for determining whether products and the information in this document are appropriate for Customer's use and for ensuring that Customer's workplace and disposal practices are in compliance with applicable laws and other government enactments. Dow assumes no obligation or liability for the information in this document. NO WARRANTIES ARE GIVEN; ALL IMPLIED WARRANTIES OF MERCHANTABILITY OR FITNESS FOR A PARTICULAR PURPOSE ARE EXPRESSLY EXCLUDED.

COMBUSTIBLE: THERMAX products should be used only in strict accordance with product application instructions. THERMAX products, when used in a building containing combustible materials, may contribute to the spread of fire. For more information, consult MSDS and/or call Dow at 1-866-583-BLUE (2583). In an emergency, call 1-989-636-4400.

WARNING: THERMAX insulation does not constitute a working walkable surface or qualify as a fall protection product.

Building and/or construction practices unrelated to insulation could greatly affect moisture and the potential for mold formation. No material supplier including Dow can give assurance that mold will not develop in any specific system.



Printed in U.S.A.



Living.
Improved daily.

*Trademark of The Dow Chemical Company

R DETECTOR
Ask your Dow representative
about R-Detector Life Cycle
Energy Analysis Software.

Form No. 179-04338-0804P&M